

EZ ELECTRIC POWER STEERING
INSTALLATION MANUAL
TOYOTA LAND CRUISER

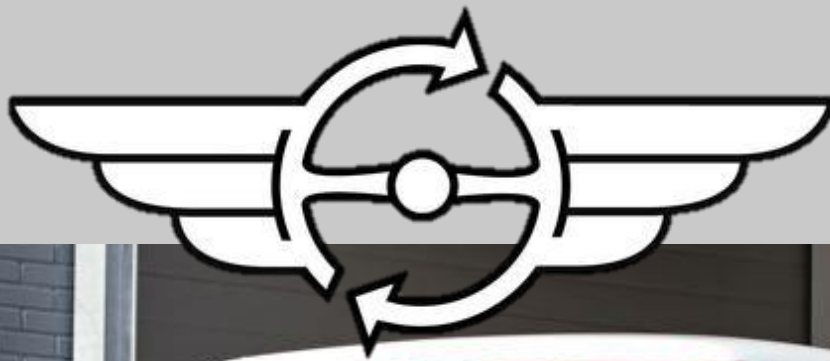

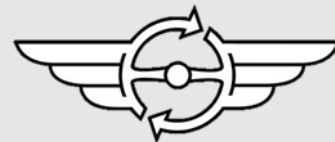

CONTENT

The Product	1
Contents of the set	2
Before and after assembly	3
Installation.....	4



THE PRODUCT

Thank you for choosing an EZ ELECTRIC POWER STEERING system for its quality, certification and easy assembly. Since 2006 we produce complete steering columns with integrated power steering. All columns are custom made for each type of car and we already have 200 types in stock! For more information about our products (power steering systems and replica steering wheels) or to place an order, visit our website www.ezpowersteering.com or send an e-mail to info@ezpowersteering.nl. If you have any questions about the installation, please contact us at workshop@ezpowersteering.nl.

Version C1.2

Date 02-02-2022

This manual should be read carefully to avoid errors. Check whether all parts of the set are present. This can be done on the basis of the picture in this manual. Before installation, compare the EZ POWER STEERING column with the original column. Check that the dimensions are the same. Also fit the steering wheel to the column.

If you do not have the skills or tools to perform the installation, have it performed by a professional. EZ POWER STEERING cannot be held liable for incorrect installation or self-inflicted damage.

The manuals are generally based on a left-hand-drive vehicle. In most cases, the right-hand drive version is the mirror image of the installation of a left-hand drive vehicle.

If you think that any changes are needed in this manual, we would like to receive your pictures and comments. With your feedback we can improve our manuals!

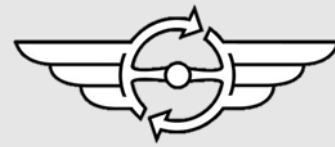

CONTENTS OF THE SET

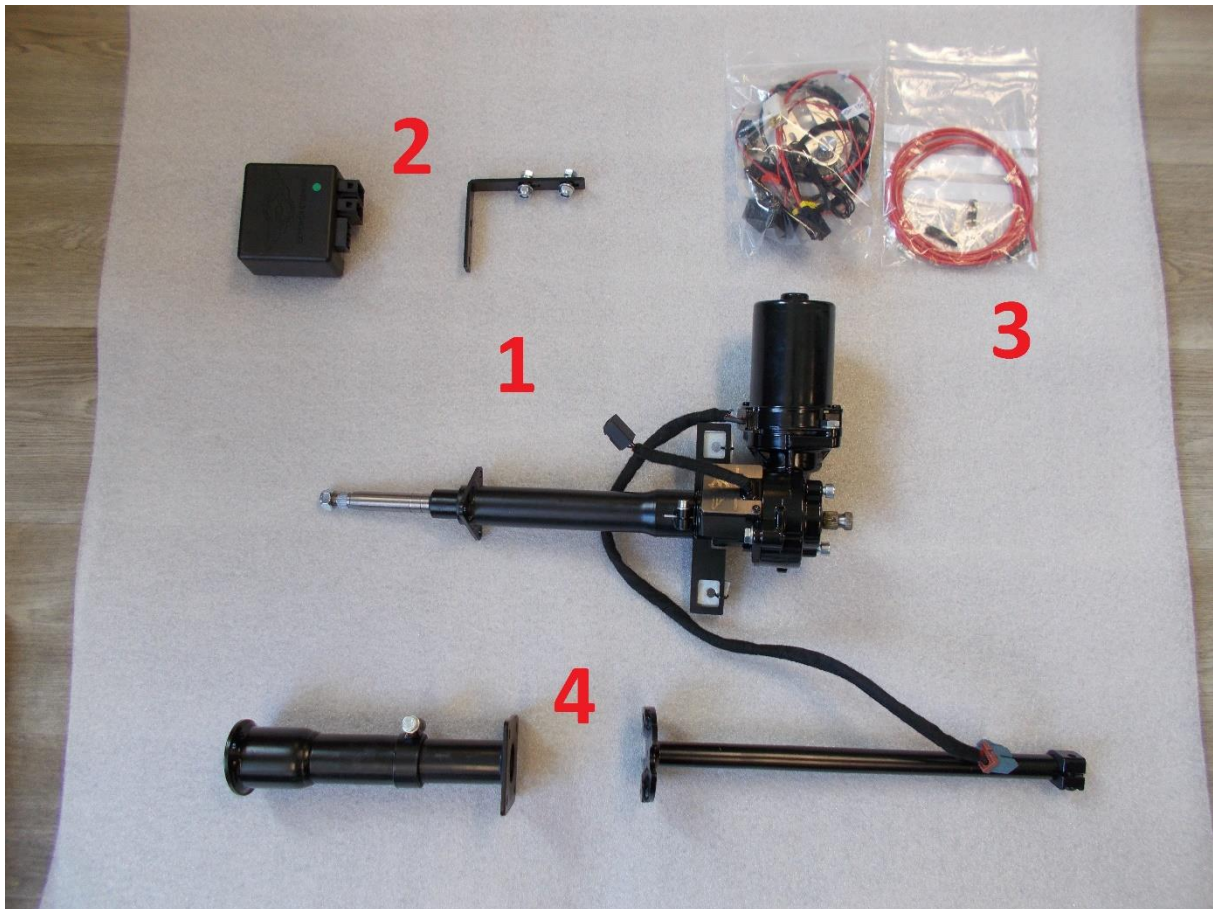

- 1 -EZ steering column.
- 2 -EZ Computer
- 3 -EZ wiring harness with controller and Power wire.
- 4- Output tube and shaft

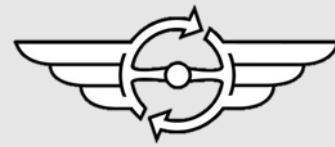

BEFORE AND AFTER ASSEMBLY



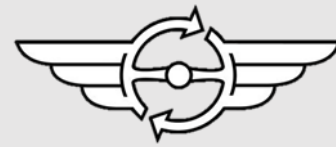

INSTALLATION

When installing the EZ Electric Power Steering unit (EZ-unit) column ensure that everything is precisely aligned so no oscillating shafts or shafts that are mounted with too much tension. Both items can worsen the self-centering effect of the steering.

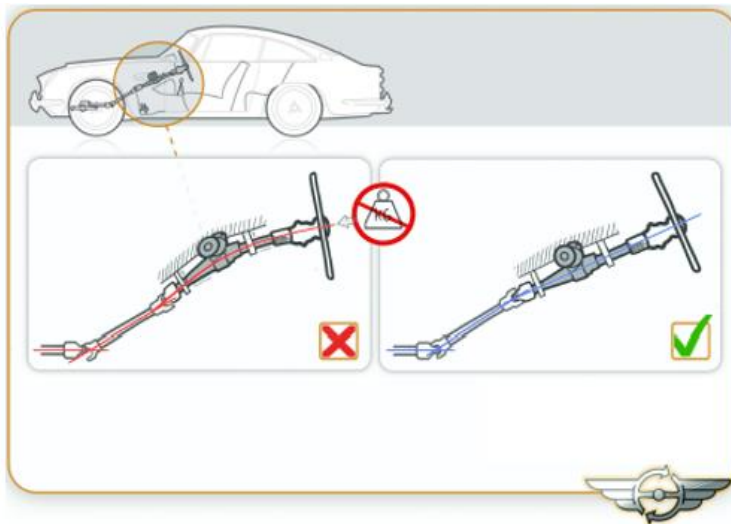

It's very important that the input shaft is **NEVER** hit with a hammer or being put under a load (radial/axial) while fitting, this will change the torque sensor settings and will cause the steering to be heavier to one side, or the unit will not work at all!

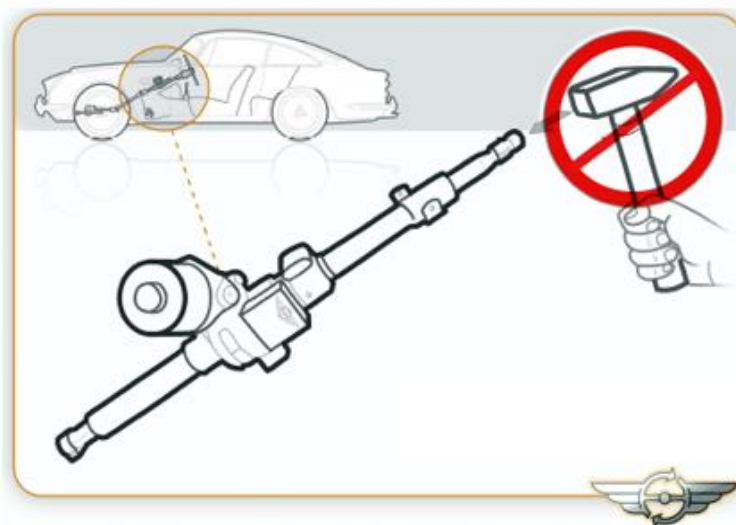

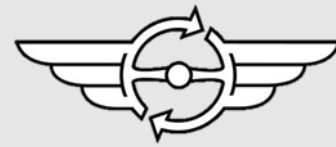

Check length, diameter and splines

Compare the EZ Power Steering Column (EZ-unit) with the original steering column before installing it. Check if the splines on the top and bottom, the diameter of the steering tube and the length of the column are all the same as the original steering column. When in doubt you can use the original steering wheel to check the top splines for fit. Never hammer on the steering shaft of the EZ unit!

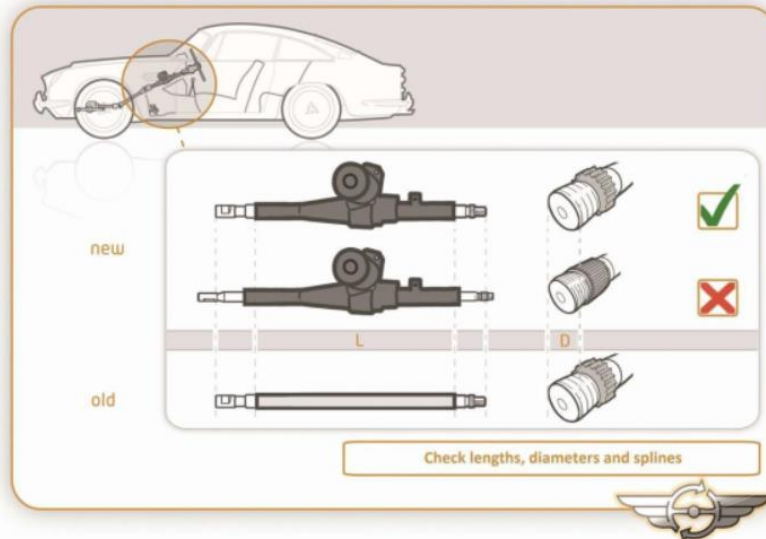

In the car industry its common to have some small tolerances in spline connections. In very exceptional cases connecting a new shaft from the EZ-unit in the original (old) U-joint could cause a tight fitting. This is sometimes relatively easy to solve by sanding only about 0,2mm (0,007 inch) in the inner part of the U-joint and also the spline on the output shaft on the EZ-unit.

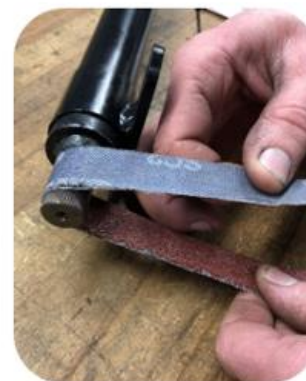



When the new steering column is being fitted hand tighten all the bolts and check if everything turns smoothly before tightening to required Torque, use torque tightening table below:

Torque tightening values in Nm.

	Alu	8.8	10.9	12.9
M6	6	11	16	19
M8	15	27	40	47
M10	25	54	79	93
M12	45	93	137	160

The system works with a torsion bar into the unit, this measures the amount of torque/load on the steering shaft while steering, the torque sensor measures this and sends a voltage to the ECU. The ECU uses this signal together with the speed signal to control the electric motor from the EZ-unit

Voltage

The basic EZ-unit, is a 12V system with negative earth!. There are extra wiring sets available, so that the kit will work with a 6V or 24V system and/or positive earth. Check your vehicle setup before fitting the EZ-unit.

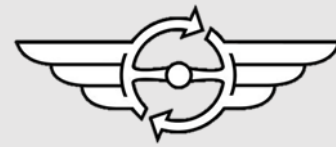

Step 1.

Check the tyre pressure and test drive the car. Check that the steering wheel returns to the centre position. Check that the steering and instruments are not faulty. If all this is in order, proceed with the conversion.

Step 2.

Find a contact-connected power supply. This is necessary to control the EZ power steering unit (see point 14). The switched-mode power supply can be tapped, for example, from the wiring harness of the ignition lock or from the fuse box. Mark this connection. Then disconnect the ground cable from the battery. Place the steering in the middle position. If desired, mark this position and proceed with the conversion.

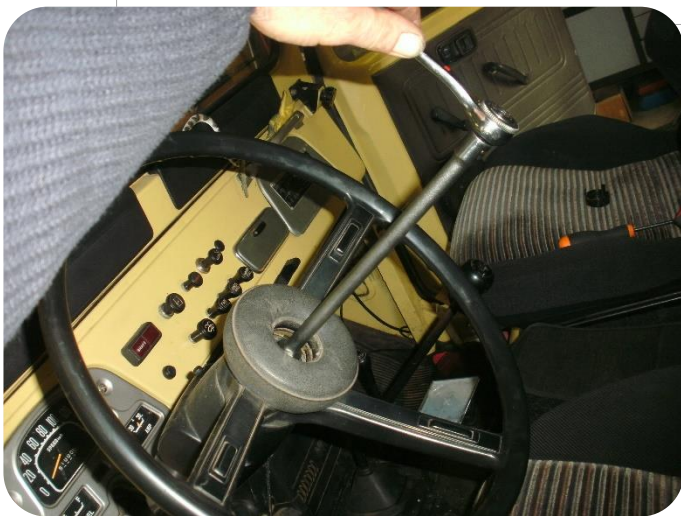

Step 3.

Dismantle the steering cap by means of three screws on the back of the handlebar, or by carefully removing the emblem from the steering cap. Dismantle the steering nut and then the handlebar. We prefer the use of a handlebar puller. Dismantle the protective caps around the steering column. Dismantle the indicator switch from the column. Then disassemble the plug of the ignition switch.



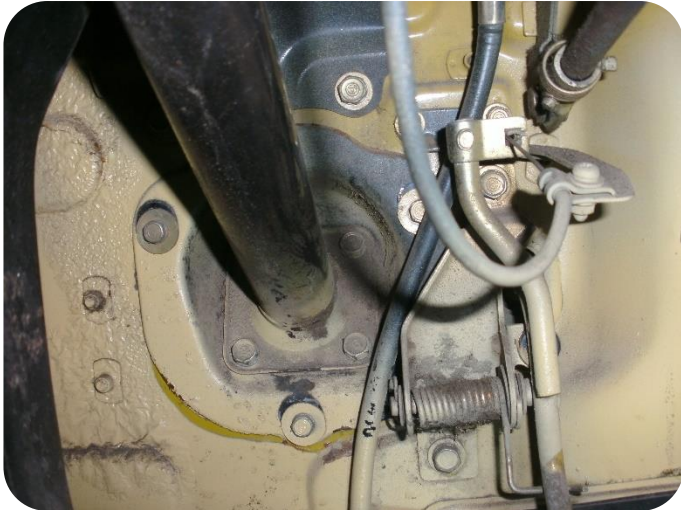
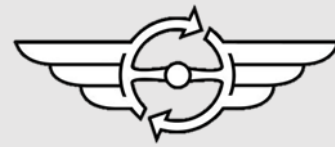

Step 4.

Dismantle the three fixing bolts on the underside of the steering column against the bulkhead. Note: these are the three outer bolts.



Step 5.

Dismantle the steering shaft coupling mounting bolts in the engine compartment.



Step 6.

After removing the upper mounting bolts on the dashboard, the column can be removed.

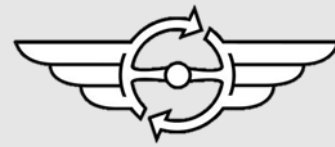

Step 7.

Remove the ignition switch from the original column and mount it on the EZ unit (it is mounted with three bolts and retaining clips).

Attention: the original locking clips must be transferred.



Step 8.

Remove the mounting bolts from the output tube of the EZ unit, . See arrows in the picture. The tube can be pushed back.

After this the clamping bolt of the output shaft can be disassembled, the output shaft can now be taken out of the output tube.



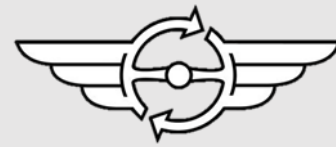

Step 9.

Remove the steering shaft from the original column. Then disassemble the base plate of the original column. This is located with either a triangular plate with 3 bolts or with a square plate and 4 bolts (depending on the version). Then mount the original base plate on the output tube of the EZ unit. Slide the EZ output shaft (with clamp) through the output tube over the teeth of the EZ unit. Pay attention to the correct position of the steering lock, compare with the original shaft.

Step 10.

Re-assemble the clamp on the output shaft. Pay attention to the correct position of the steering lock and reassemble the output shaft to the EZ unit and tighten the clamp bolt using a Torx 40 drive bit to **40 Nm**. Finally, tighten both pipe mounting bolts.

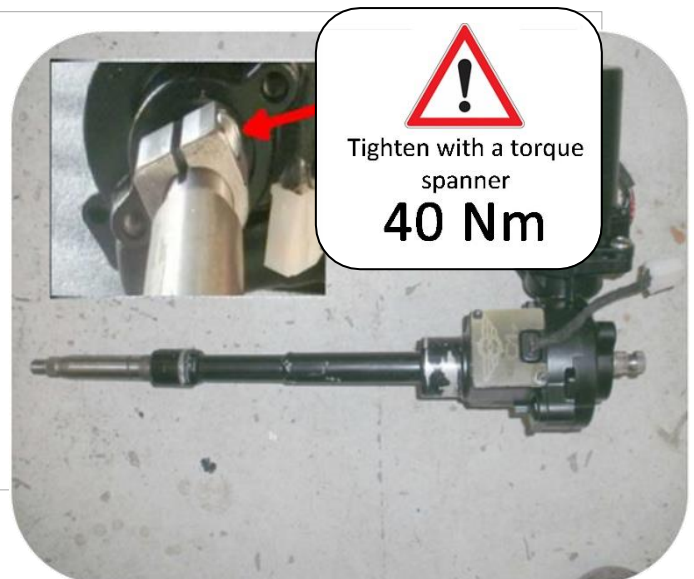

Step 11.

To provide enough space for the electric motor of the EZ unit, part of the sheet metal must be removed under the dashboard.

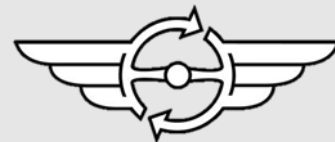

Step 12.

Mount the ECU with the supplied bracket behind the fuse box, on the left side next to the pedals. Drill 2 holes of 8mm in the bulkhead. Use the ECU with bracket to mark the holes first. Then connect the EZ wiring harness to the ECU and EZ unit.



FOR A 12V BATTERY WITH A NEGATIVE EARTH

Step 13.

Connect the thick red wire supplied (30+) directly to the battery plus via the fuse holder. It is wise to insulate the wire with an extra sheath.

Step 14.

Connect the thin red wire (15+) to a contact-switched power supply (see point 2).

Step 15.

Connect the black wire (31-) to a suitable clean earth point.

Step 16.

Find a suitable place under the dashboard to place the potentiometer.

GO TO STEP 26

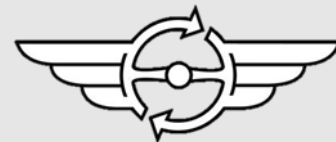

FOR A 24V BATTERY WITH A SINGLE BATTERY SETUP (DIAGRAM IN ANNEX)

Step 17.

Connect the thick red wire (30+) directly to the positive terminal of the battery whose negative terminal is connected to earth. By doing this you get 12V.

Step 18.

Connect the contact-switched wire (15+) of the EZ wiring harness to the contact-switched 24V plus in step 2. This setup uses a 24V relay, which switches the 12V for the EZ unit.

Step 19.

Connect the black wire (31-) to a suitable clean earth point.

Step 20.

Find a suitable place under the dashboard to place the potentiometer.

GO TO STEP 26



FOR A 24V BATTERY WITH OPTIONAL CONVERTER SETUP (DIAGRAM IN ANNEX)

Step 21.

Connect the INPUT connection via a relay directly to the battery 24V plus. The relay is needed to switch the device on and off. This relay is switched via the contact switched 24V plus.

Step 22.

Connect the ground connection to a suitable ground point on the chassis using a 6 mm² wire.

Step 23.

Connect the OUTPUT connector to the 12V plus (30+) and the contact switched 12V (15+) of the EZ wiring harness.

Step 24.

See the attached diagram for more details.

Step 25.

Find a suitable place under the dashboard to place the potentiometer.

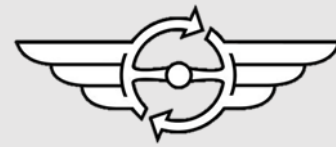

Step 26.

Loosen the lower mounting clamp so that the column can be brought into the correct position. Mount the EZ unit in the car. Make sure that the wiring of the indicator switch and ignition lock is over the top column support and the position of the steering lock. Install the top column bolts. Do not tighten all mounting points yet.



Step 27.

Mount the steering shaft clutch on the steering rack. Fasten the lower 3 footplate fixing bolts to the bulkhead. After this, tighten all mounting bolts together with the mounting clamp.

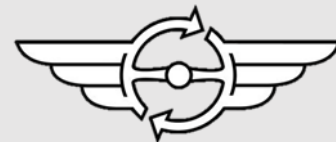

Step 28.

Install the steering column switches and the protective caps back in the car.

Step 29.

Install the previously disconnected battery ground cable. After switching on the ignition a click can be heard from the ECU, the system is now operational, check this by making steering movements. After switching off the ignition, a click can be heard again after about 4 seconds. The system is then switched off.

Step 30.

Mount the steering wheel of the car. Pay attention to the correct position! Make a test drive and check all systems again. Also check if the position of the steering wheel is correct, if not adjust it.

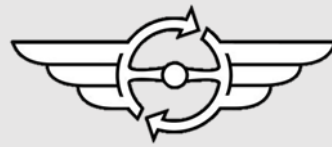

Step 31.

The end result.



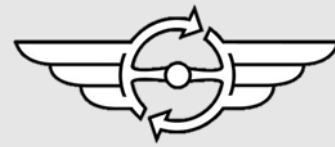
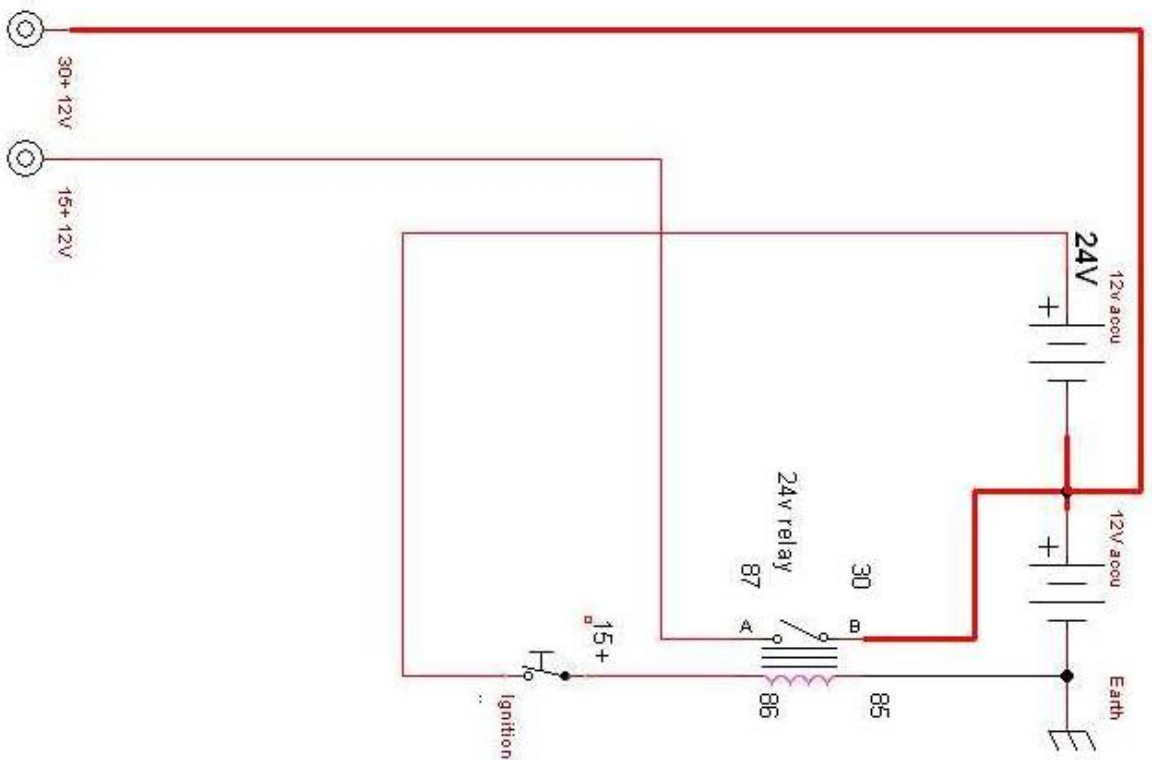

DIAGRAM: VEHICLE WITH 12V VOLTAGE.



Title	24V-12V	
Author	EZ Powersteering	
File	I:\TECHNI-1\ELEKTR-1\PVG\Klaan\24V12V.dsn	
Revision	Date	Sheets
1.0		1 of 1

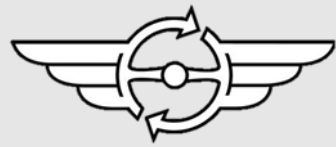
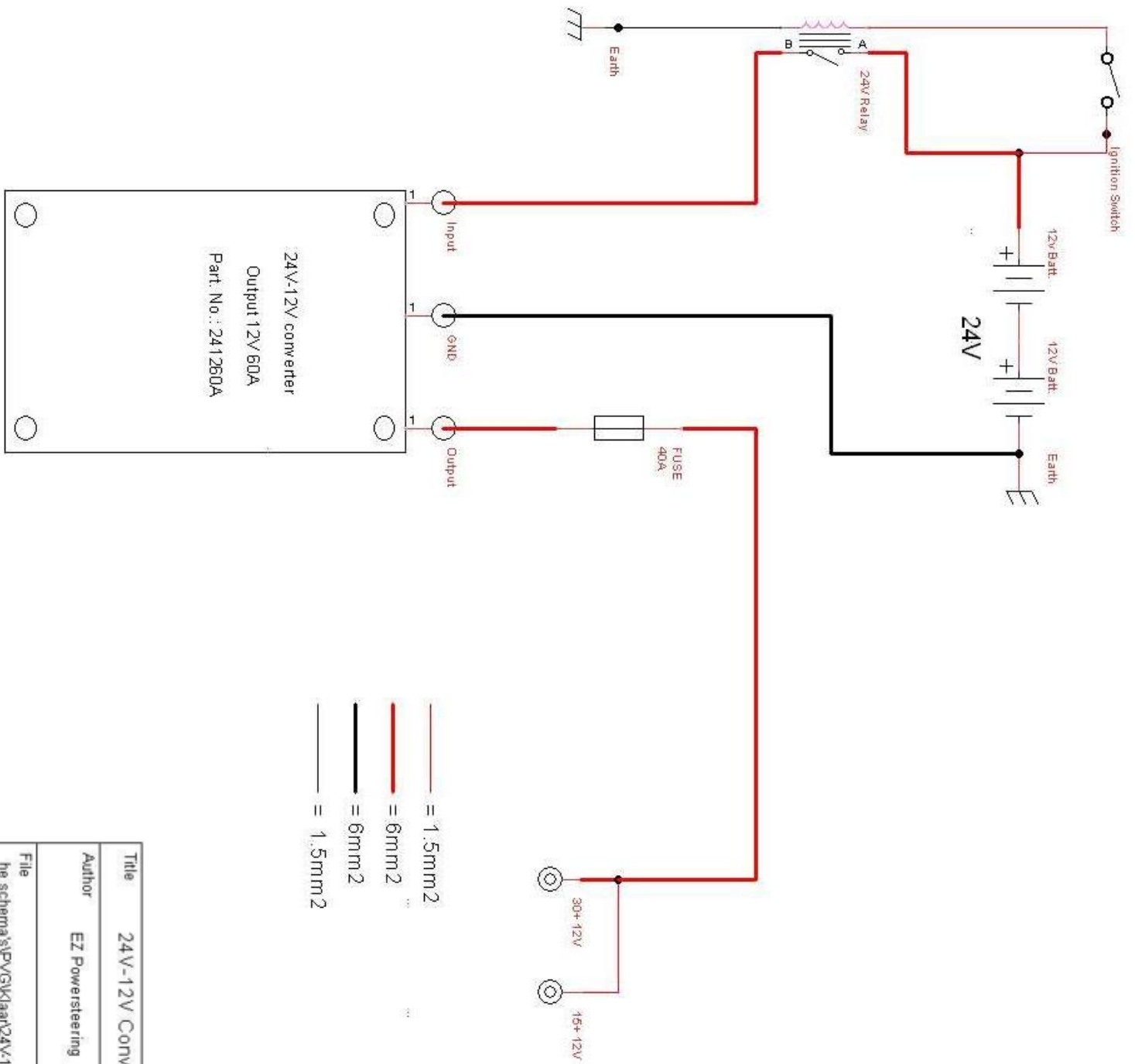

DIAGRAM: VEHICLE WITH A 24V>12V CONVERTER (OPTIONAL)



24V-12V converter

Title	24V-12V Converter	
Author	EZ Powersteering	
File	he schema s\p\vgk\kaar\24v-12v With relay DSN	Document
Revision	Date	Sheets
1.0		1 of 1

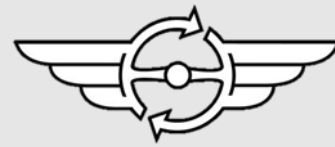

DIAGRAM: 24V AND A SINGLE BATTERY SETUP.

