

EZ ELECTRIC POWER STEERING
INSTALLATION GUIDE
JAGUAR XK120

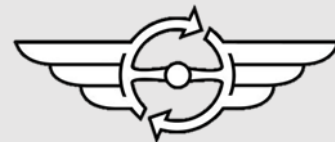



CONTENT

The Product	1
Contents of the set	2
Before and after assembly	3
Installation.....	4



THE PRODUCT

Thank you for choosing an EZ ELECTRIC POWER STEERING product for its quality, it's performance, type approval and its straightforward assembly. Since 2006 we have been manufacturing complete steering columns with integrated electrical assistance. All columns are tailor made for each type of car and we have over 200 different types in stock. For more information about our products (power steering systems and replica steering wheels) or to place an order, visit our website www.ezpowersteering.com or send an e-mail to info@ezpowersteering.nl. If you have any questions of a technical nature please contact workshop@ezpowersteering.nl.

Version C1

Date 25/3/20

This installation manual must be read very carefully to avoid mistakes.

Check if all parts are present in the kit using the picture in the manual.

Compare the EZ Power Steering Column with the original column. Examine if the sizes are similar.

If you do not have the skills or tools to carry out the installation, then have a professional fit the kit for you.

EZ Power Steering cannot be held accountable for a faulty installation or damages to the kit or vehicle.

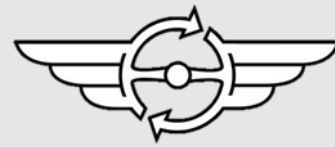

CONTENTS OF THE SET



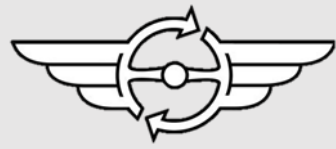

BEFORE AND AFTER ASSEMBLY



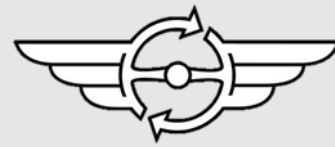

INSTALLATION

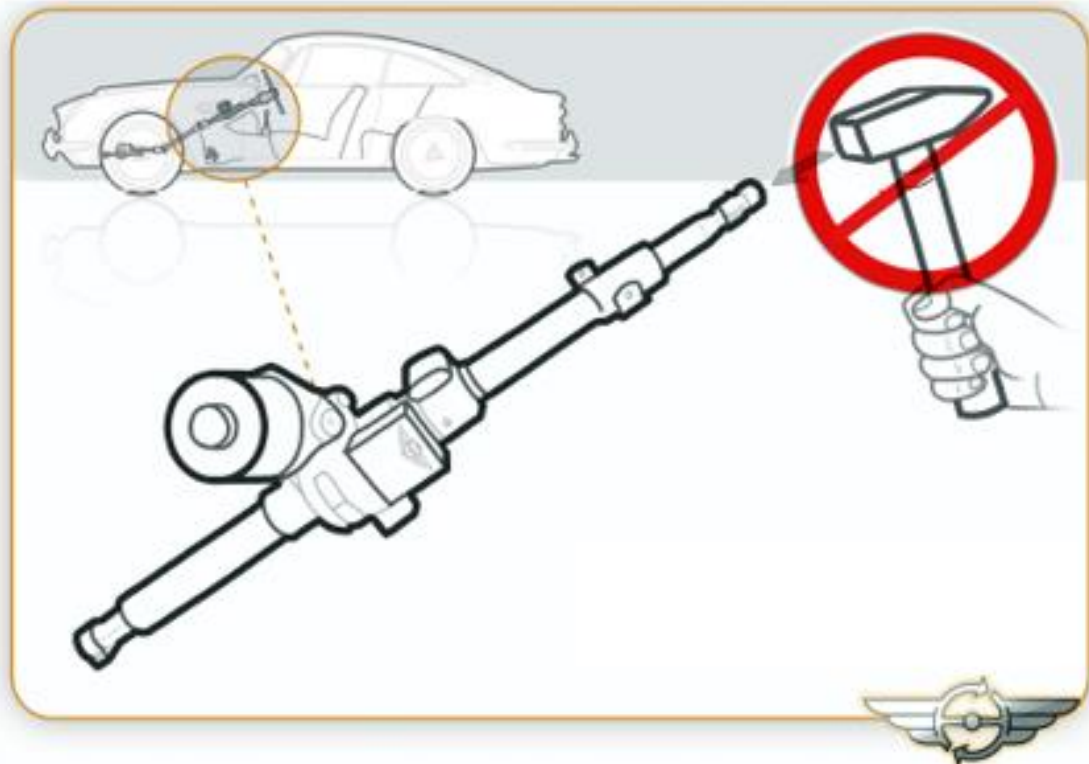

Never strike the input shaft with an object during or after assembly. This can adversely affect the sensors.

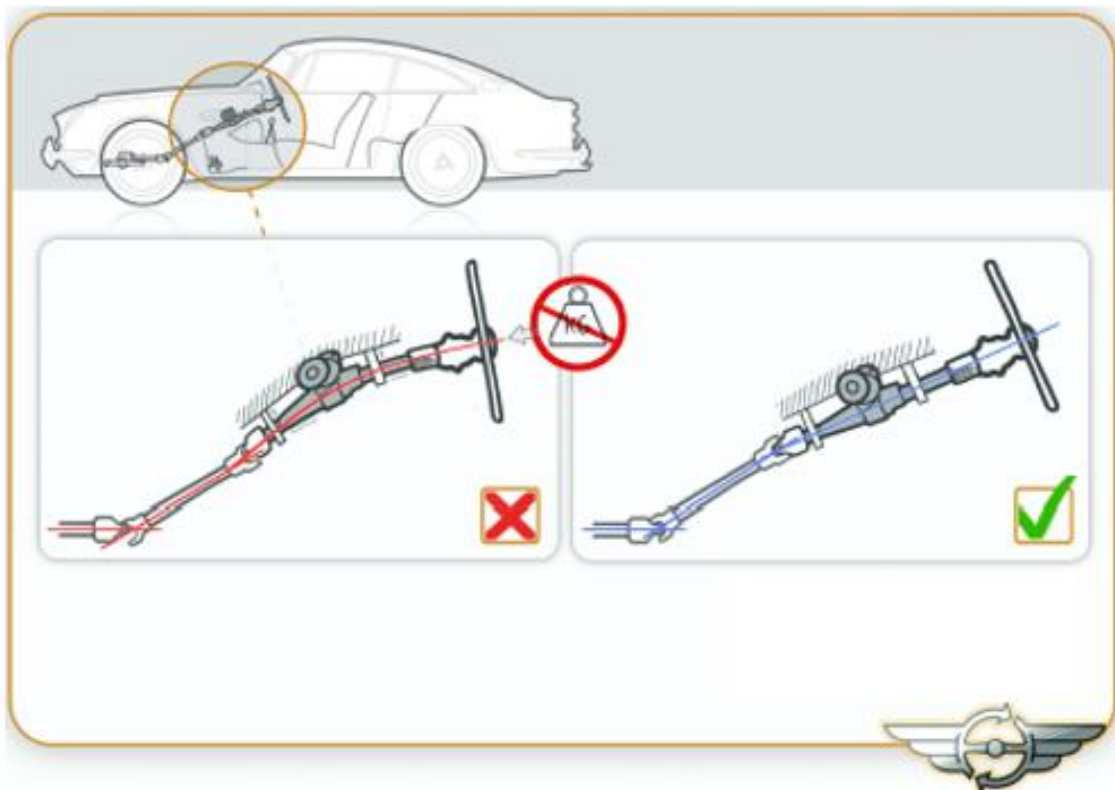

The steering system must always be properly aligned and mounted without tension.

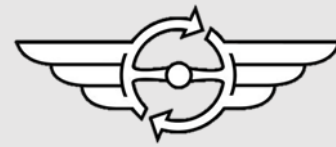

Step 1.

Check the tire pressure and test drive the car. Check that the handlebars return to the straight ahead position. Check that the controls and instruments are free from defects. If all this is in order, proceed with the conversion.

Step 2.

Find a contact-switched power supply. This is necessary for controlling the EZ power steering unit (see point 25). If present, disassemble the bottom plate under the dashboard, the switched power supply can be removed from the ignition lock. Then disconnect the earth cable from the battery.



Step 3.

Remove the direction indicator switch from the steering wheel and pull it out of the steering axle as far as possible. If necessary, feed the wire from below to the wheelhouse to provide more space. Cut the wire at the switch - make sure it stays long enough to reconnect the wires from the EZ unit at Step 29. Pull the remaining wires out of the steering box from below.

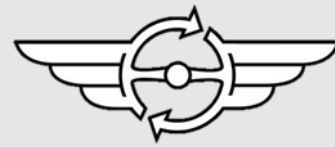

Step 4.

Remove the retaining clip, then remove the handlebar.



Step 5.

Remove the top clamp mounting from the steering column just behind the dashboard panel

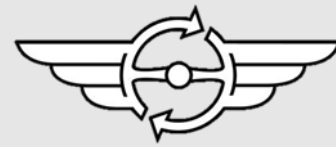

Step 6.

Cut the pipe in the engine compartment with a ratchet pipe cutter. Then remove the top section

NOTE: With an RHD car it is necessary to remove the rear carburettor. See the image in Step 7 for more details.



Step 7.

Measured from the bulkhead, the tube should be cut to 400 mm (15.75 in).

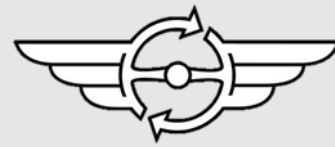

Step 8.

Now cut through the steering shaft. Put a cloth in the steerer tube to prevent filing from entering the tube. Measured from the bulkhead, cut the shaft to 220 mm (8.75 inches).

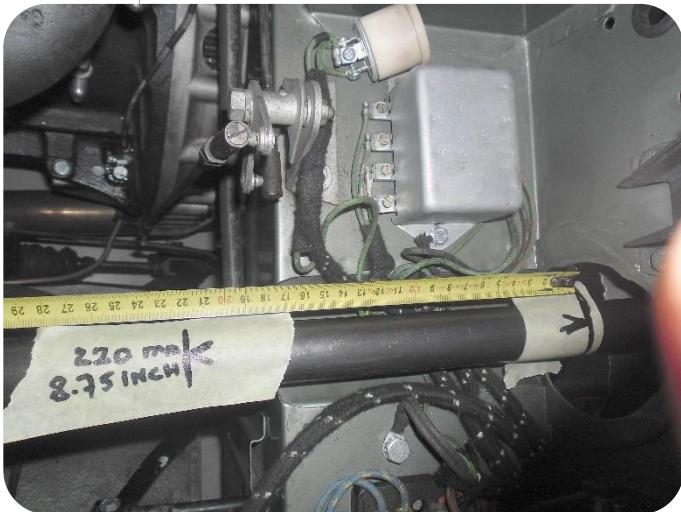

Step 9.

Remove the sawn-off parts of the steerer tube and steering axle. Then loosen the clamp of the stator tube at the bottom of the wheelhouse.

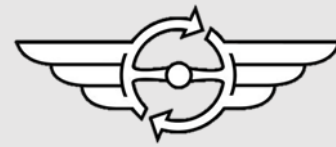

Step 10.

Use a hammer with a round rod to tap the small pipe (stator tube) out of the wheelhouse.



Step 11.

Tap the stator tube about 20 cm and cut off the protruding part.
Then tighten the clamp again



Step 12.

Disassemble the EZ set into separate parts as shown in the photo on the front cover.

Take the output tube no.3 with clamp and the grommet rubber from the bulkhead and slide it over the tube of the original steering column



Step 13.

To give the EZ unit sufficient space, a recess must be made in the original sheet metal. Please see the photos for details. The two existing openings must be merged into one larger opening. NOTE: This manual is for an LHD vehicle. In the case of a RHD vehicle, a mirror image can normally be used. Use the EZ unit to determine where to cut.





Step 15.

Place the output flange in the car. The EZ unit can be retrofitted to the car.



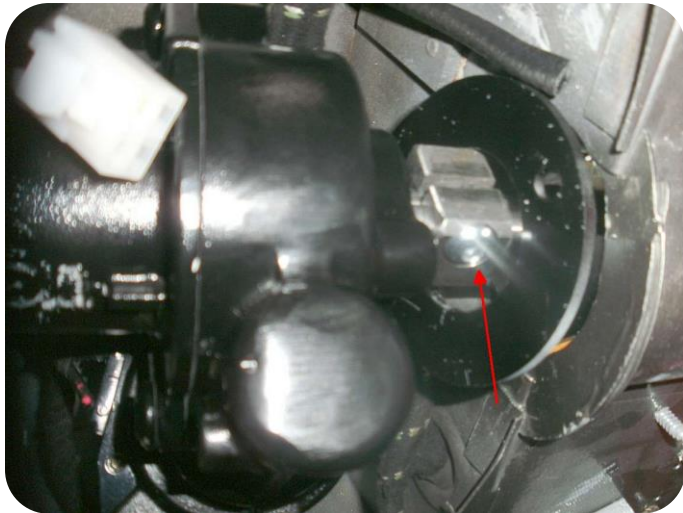
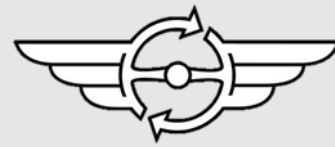

Step 16.

Install the output shaft on the unit.



Step 17.

Secure the input tube with the original clamp.

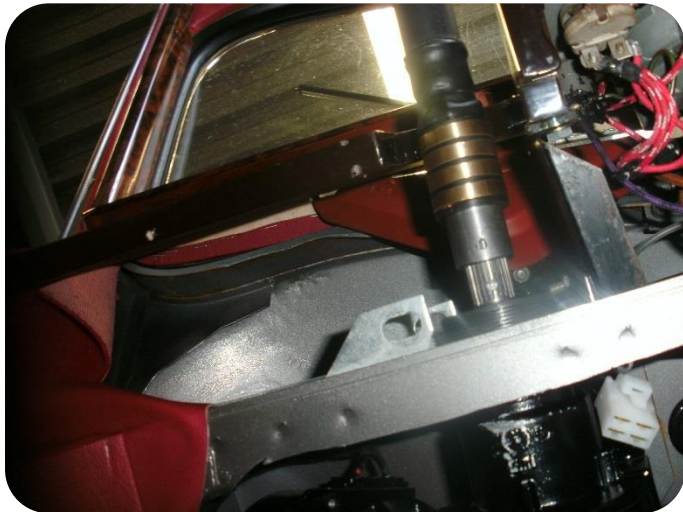
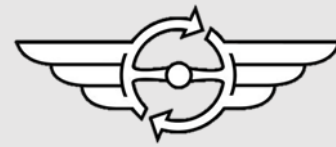

Step 18.

Install the input shaft and secure it with the Allen screw. Use Lock-tite when performing the final installation of this bolt.



Step 19.

Install / screw the inlet tube to the EZ unit.



Step 20.

Install the output flange on the EZ unit.

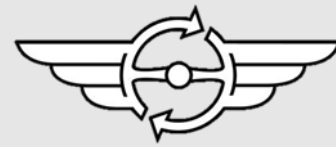

Step 21.

Temporarily mount the output pipe on the EZ unit. Check the alignment and protrusion distance from the dashboard. Also check the position of the slip rings relative to the contact pins.

If everything is placed correctly, tighten the input tube locknut and clamp it off the input pipe and mount the holder.

Step 22.

Remove the output pipe from the unit, it can be slid over the original pipe. Weld the EZ output shaft (041-3) on the original steering shaft. Slide the output tube to its original position and lock it with the locknut, then tighten the clamp.

Install the previously installed cover around the steerer tube and firewall (see Step 12).

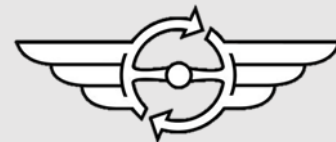

Step 23.

Connect the EZ wire harness to the ECU.

Step 24.

Connect the thick red wire (30+) supplied via the fuse holder directly to the battery plus. It is advisable to insulate the wire with an extra jacket.

Step 25.

Connect the thin red wire (15+) to a contact-switched power supply (see point 2)

Step 26.

Connect the black wire (31-) to a suitable clean ground point.

Step 27.

Install the previously disconnected earth cable from the battery. After switching on the ignition, a click is heard from the ECU, the system is now operational, check this by making steering movements. After switching off the ignition, a click is heard again after about 4 seconds. The system is then disarmed.

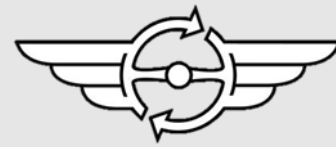

Step 28.

Install the steering wheel of the car again. Or mount the steering wheel in the straight-ahead position and test the operation of the power steering. Install the contact pins in the holder. ATTENTION: do not over tighten them! Take the harness from the direction indicator that was removed from the steering box in Step 3 and route it via the bulkhead to the contact pins. Connect the wiring of the turn signal and horn to the contact pins. Insulate the wiring in the steering axle.

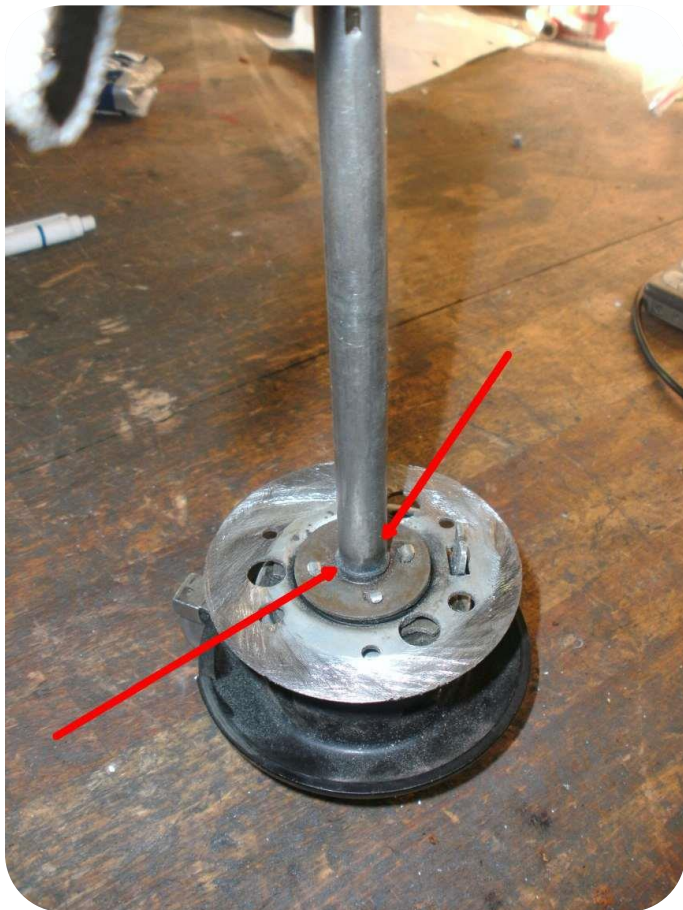

Step 29.

Shorten the tube of the indicator switch as much as possible. Remove any sharp edges from the metal and use a piece of heatshrink to protect the wires. Make sure to leave the wires long enough to reconnect them. Ensure that the inner ring and outer ring can no longer turn independently. Jam them by using a spot weld or screw.



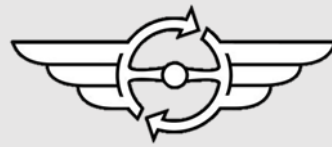

Step 30.

Take a test drive and check all systems again. Also check if the steering wheel position is correct, if not adjust it. Reattach the dashboard bottom plate.

Step 31.

The end result.

