

EZ ELECTRIC POWER STEERING
INSTALLATION MANUAL
FORD MUSTANG 1964-1967

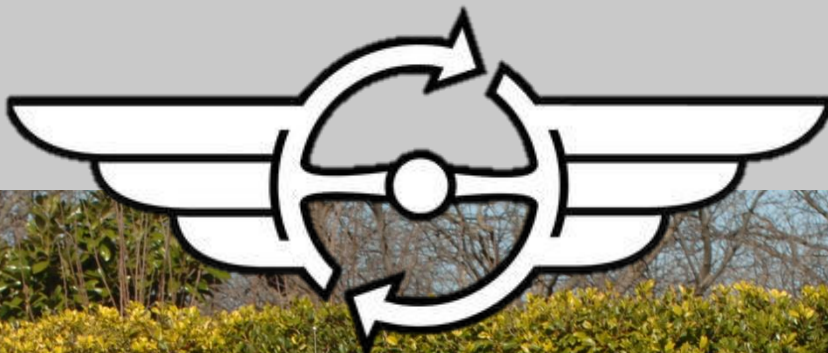

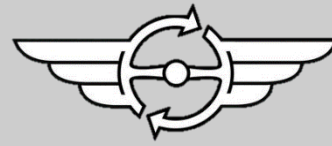

CONTENTS

1. THE PRODUCT _____	3
2. OVERVIEW OF THE KIT _____	4
3. INSTALLATION _____	5

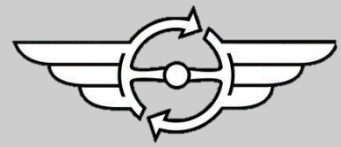

THE PRODUCT

Thank you for choosing an EZ ELECTRIC POWER STEERING product for its quality, it's performance, type approval and its straightforward assembly. Since 2006 we have been manufacturing complete steering columns with integrated electrical assistance. All columns are tailor made for each type of car and we have over 200 different types in stock. For more information about our products (power steering systems and replica steering wheels) or to place an order, visit our website www.ezpowersteering.com or send an e-mail to info@ezpowersteering.nl. If you have any questions of a technical nature please contact workshop@ezpowersteering.nl.

Version C1.2

Date 04-02-2022

This manual should be read carefully to avoid errors. Check whether all parts of the set are present.

This can

be done on the basis of the picture in this manual. Before installation, compare the EZ POWER STEERING column with the original column. Check that the dimensions are the same. Also fit the steering wheel to the column.

If you do not have the skills or tools to perform the installation, have it performed by a professional.

EZ

POWER STEERING cannot be held liable for incorrect installation or self-inflicted damage.

The manuals are generally based on a left-hand-drive vehicle. In most cases, the right-hand drive version is

the mirror image of the installation of a left-hand drive vehicle.

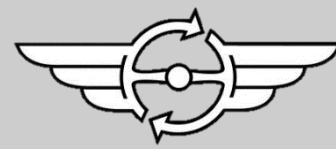

OVERVIEW OF THE KIT

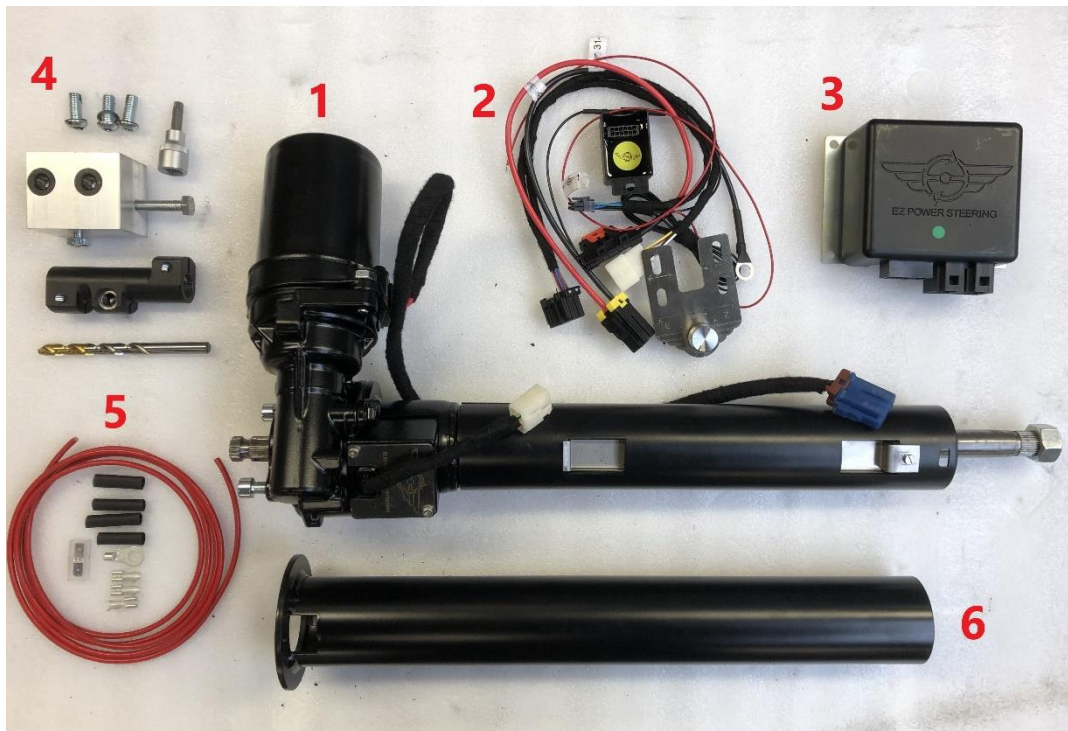

- EZ-FMUST-1. Complete set
- EZ-FMUST-2. Wire harness with controller
- EZ-FMUST-3. ECU
- EZ-FMUST-4. Drilling block
- EZ-FMUST-5. 6mm² Electric cable
- EZ-FMUST-6. Output tube

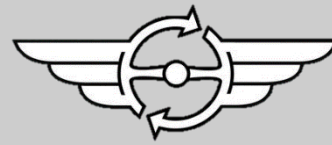

INSTALLATION

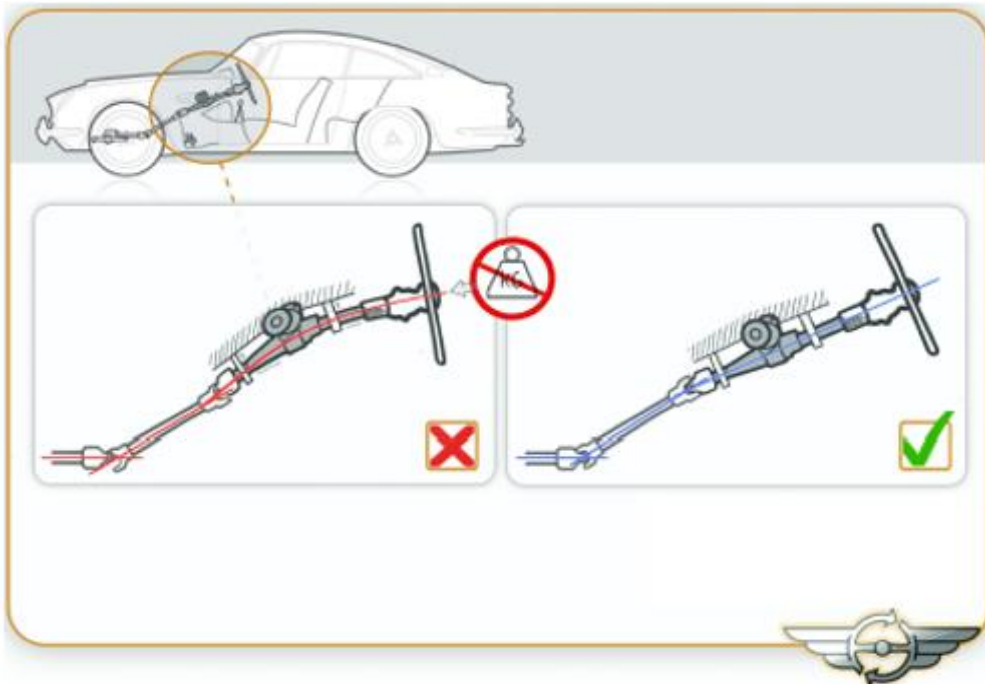

The steering system must always be properly aligned and mounted without tension.

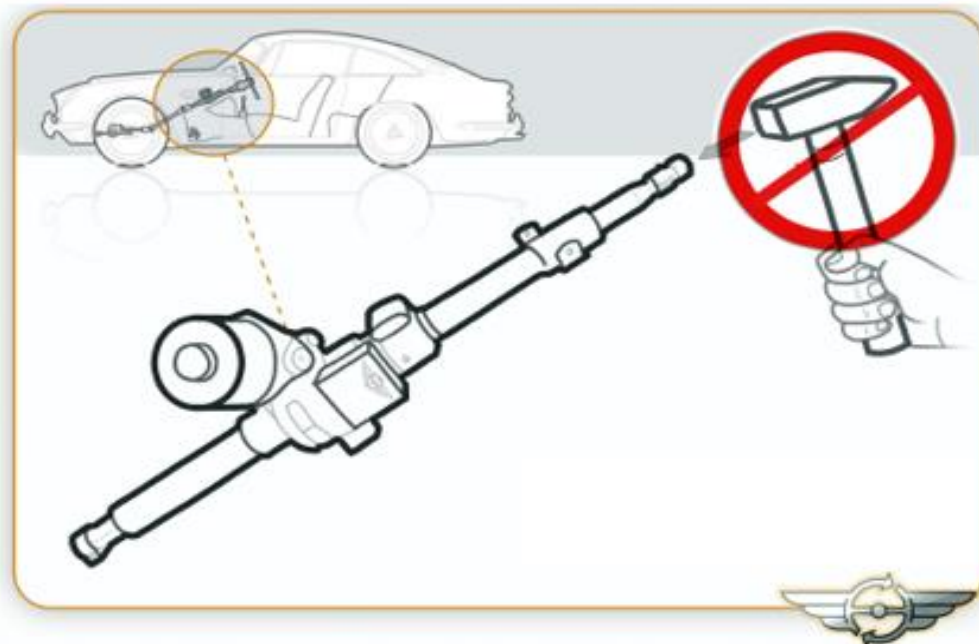

Never strike the input shaft with an object during or after assembly. This can adversely affect the sensors.

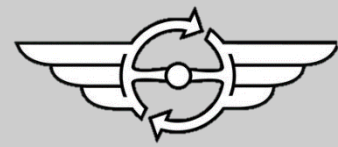

Check length, diameter and splines

Compare the EZ Power Steering Column (EZ-unit) with the original steering column before installing it. Check if the splines on the top and bottom, the diameter of the steering tube and the length of the column are all the same as the original steering column. When in doubt you can use the original steering wheel to check the top splines for fit. Never hammer on the steering shaft of the EZ unit!

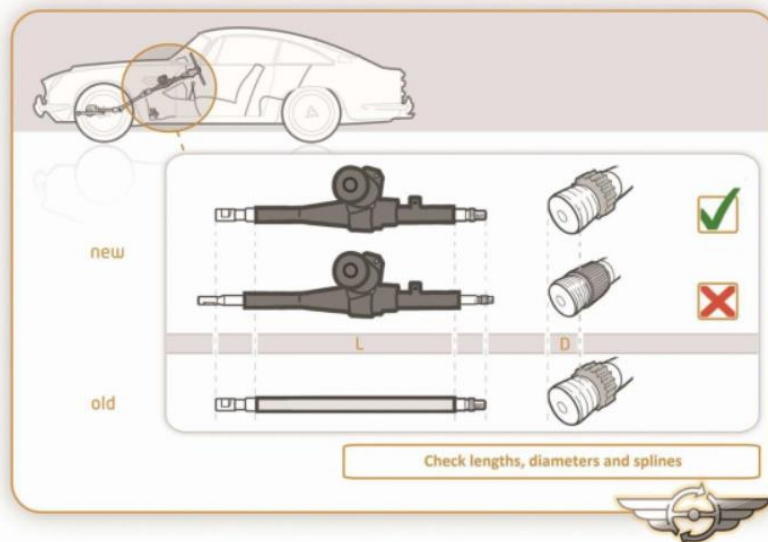

In the car industry its common to have some small tolerances in spline connections. In very exceptional cases connecting a new shaft from the EZ-unit in the original (old) U-joint could cause a tight fitting. This is sometimes relatively easy to solve by sanding only about 0,2mm (0,007 inch) in the inner part of the U-joint and also the spline on the output shaft on the EZ-unit.





Torque tightening values in Nm.

When the new steering column is being fitted hand tighten all the bolts and check if everything turns smoothly before tightening to required Torque, use torque tightening table below:

	Alu	8.8	10.9	12.9
M6	6	11	16	19
M8	15	27	40	47

The system works with a torsion bar into the unit, this measures the amount of torque/load on the steering shaft while steering, the torque sensor measures this and sends a voltage to the ECU. The ECU uses this signal together with the speed signal to control the electric motor from the EZ-unit

Voltage

The basic EZ-unit, is a 12V system with negative earth! There are extra wiring sets available, so that the kit will work with a 6V or 24V system and/or positive earth. Check your vehicle setup before fitting the EZ-unit.

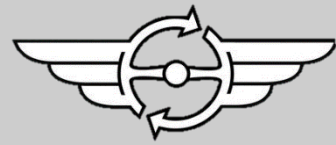

Step 1.

Check tire pressures and take the car for a test drive. Check the original steering system for faults and alignment. As long as everything is working correctly, then continue with the conversion.

Step 2.

Locate an ignition-switched feed wire and mark this wire (see step 18). This needed to switch the unit on/off. Disconnect the earth cable from the battery afterwards.



Step 3.

Remove the horn button and steering wheel.

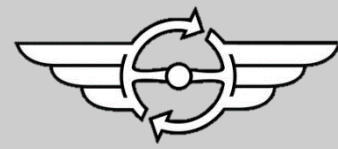

Step 4.

Unscrew the lever from the indicator switch.

Remove the three screws from the indicator switch. Also, remove the two installation bolts from the switch holder/cover at the top of the steering column.

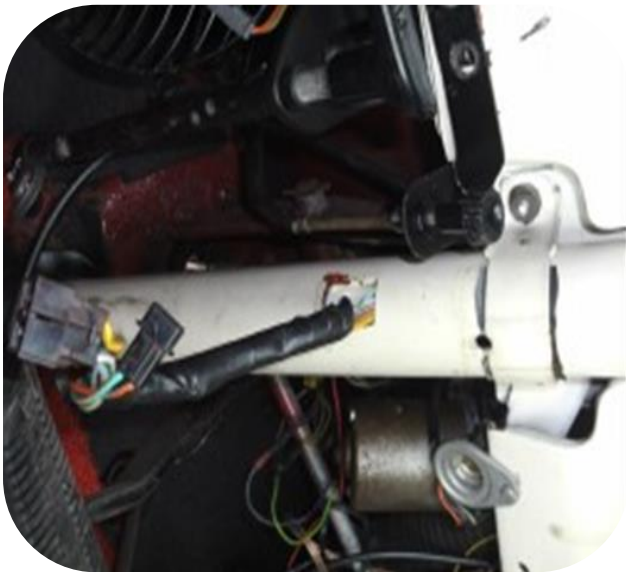

Step 5.

Disconnect the connectors from the steering column.

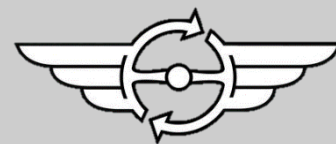

Step 6.

Remove the upper installation bolts from the steering column.



Step 7.

Remove the installation bolts from the parking brake bracket.

The original column can now be removed.

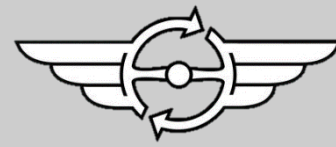

Step 8.

Remove the indicator switch from the original column and install in onto the EZ unit.

NOTE: to make the removal from the wires easier it's advisable to bend the guidance from the wires (see photo).

Do not forget to slide the lower part over the EZ column prior to the installation from the switch and wiring.



Step 9.

To determine how much must be cut from the original steering shaft, measure the EZ column: measure the total length, minus the inner depth from the coupler. This is the total length that needs to be cut – note this value.

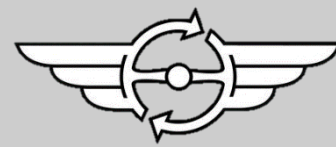

Step 10.

Measure this distance back from the top of the original steering shaft. Mark this and cut the shaft. Be sure that there will be a straight cut.

Note: Use some tape to mark the cutting line, this can also be used as a guideline during cutting.



Step 11.

Slide the drilling tool over the remaining original steering shaft. Lock the tool with the bolt (red arrow). Now you can use the supplied 8.5mm drill to drill the recesses in the steering shaft.

NOTE: ensure that the steering system is fully steered to the left, this prevents unwanted rotation from the steering shaft while drilling.

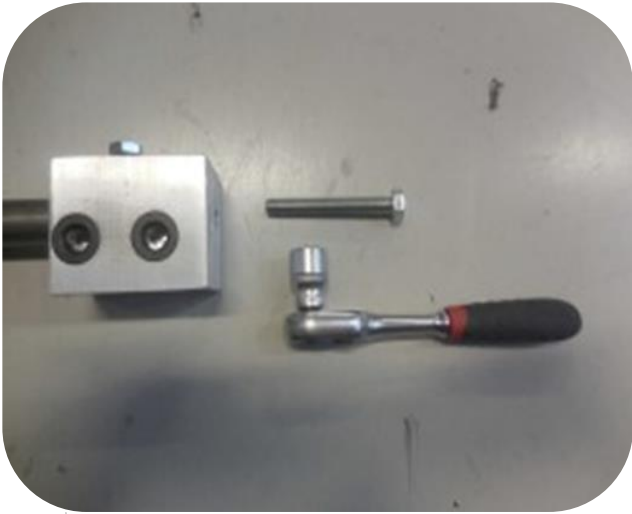
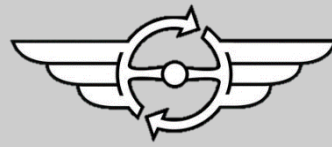

Step 11a.

To remove the drilling tool from the shaft, there is thread tapped at the back of the tool. Use a long M8 bolt to push the tool off the shaft.

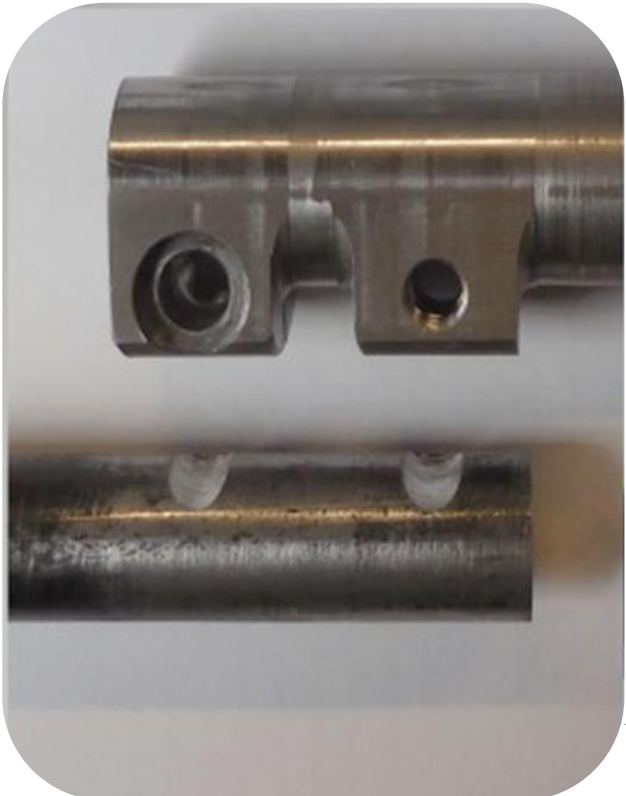

Step 12.

These recesses are needed to give enough clearance for the clamping bolts from the clamp.

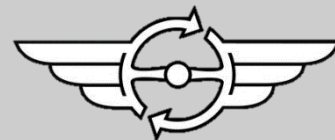

Step 13.

Clean/degrease the shaft after drilling and check if the clamp can be fitted over the original steering shaft, see if the recesses are located OK to install the bolts. If everything is correct, continue with the conversion.



Step 14.

Install both bolts and tighten them with 35NM /26 FOOT/POUND. Do not forget the washers underneath these bolts.

Remove the output tube from the EZ unit and slide it over the original shaft with clamp.

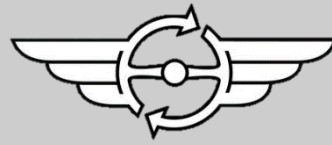

Step 15.

Install the EZ unit into the car and tighten it. The bolt from the clamp/adaptor can be tightened through an opening in the output tube.

The original upper bracket can be reused. Hand-tighten this (see step 22).

Connect the original steering column connectors.



Step 16.

Locate a suitable location for the EZ ECU and install it. Connect the EZ wire harness with the ECU afterwards.

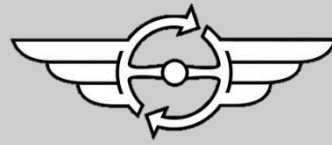

Step 17.

Connect the thick red wire (30+) via the fuse holder directly to the battery +.

Step 18.

Connect the thin red wire (15+) to an ignition switched feed wire (see step 2).

Step 19.

Connect the black wire (31-) to a suitable earth point on the car.

Step 20.

Locate a suitable place for the potentiometer and install it.

Step 21.

Reinstall the parking brake bracket.

Step 22.

Install the steering wheel, with horn button, onto the EZ column. Check the clearance between the steering wheel and column, if needed adjust it. Tighten the upper bracket afterwards (see step 15).

Step 23.

Reconnect battery earth.

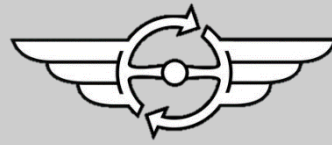

Step 24.

After the ignition has been switched on there is a click noticeable from the ECU. The system is now operational. Check this. After the ignition has been switched off the system turn off with a delay. This is noticeable by the click a couple seconds after the ignition has been switched off.

Step 25.

Take the car for a test drive and check that the steering is functioning correctly. Check the steering wheel position and adjust if needed. Be sure the indicator switch is functioning correctly.