

# **EZ ELECTRIC POWER STEERING INSTALLATION MANUAL**

**FERRARI DAYTONA, 365GTB/4, 365GTS/4**

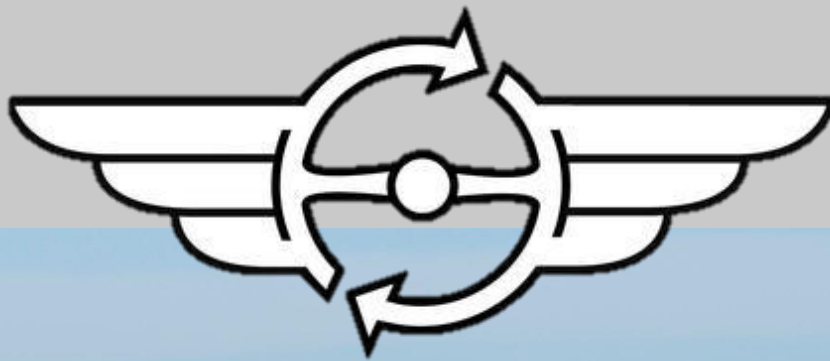



# CONTENT

Het Product .....	1
Contents of the set .....	2
Before and after assembly .....	3
Installation.....	4

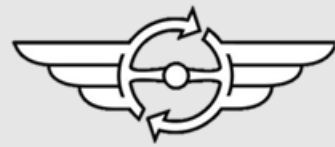

## HET PRODUCT

Thank you for choosing an EZ ELECTRIC POWER STEERING product for its quality, its performance, type approval and its straightforward assembly. Since 2006 we have been manufacturing complete steering columns with integrated electrical assistance. All columns are tailor made for each type of car and we have over 200 different types in stock. For more information about our products (power steering systems and replica steering wheels) or to place an order, visit our website [www.ezpowersteering.com](http://www.ezpowersteering.com) or send an e-mail to [info@ezpowersteering.nl](mailto:info@ezpowersteering.nl). If you have any questions of a technical nature please contact [workshop@ezpowersteering.nl](mailto:workshop@ezpowersteering.nl).

Version C1

Date 12/2/20

*This installation manual must be read very carefully to avoid mistakes.*

*Check if all parts are present in the kit using the picture in the manual.*

*Compare the EZ Power Steering Column with the original column. Examine if the sizes are similar.*

*If you do not have the skills or tools to carry out the installation, then have a professional fit the kit for you.*

*EZ Power Steering cannot be held accountable for a faulty installation or damages to the kit or vehicle.*

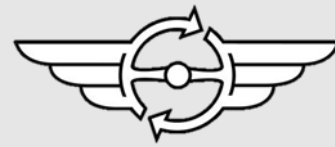

# CONTENTS OF THE SET

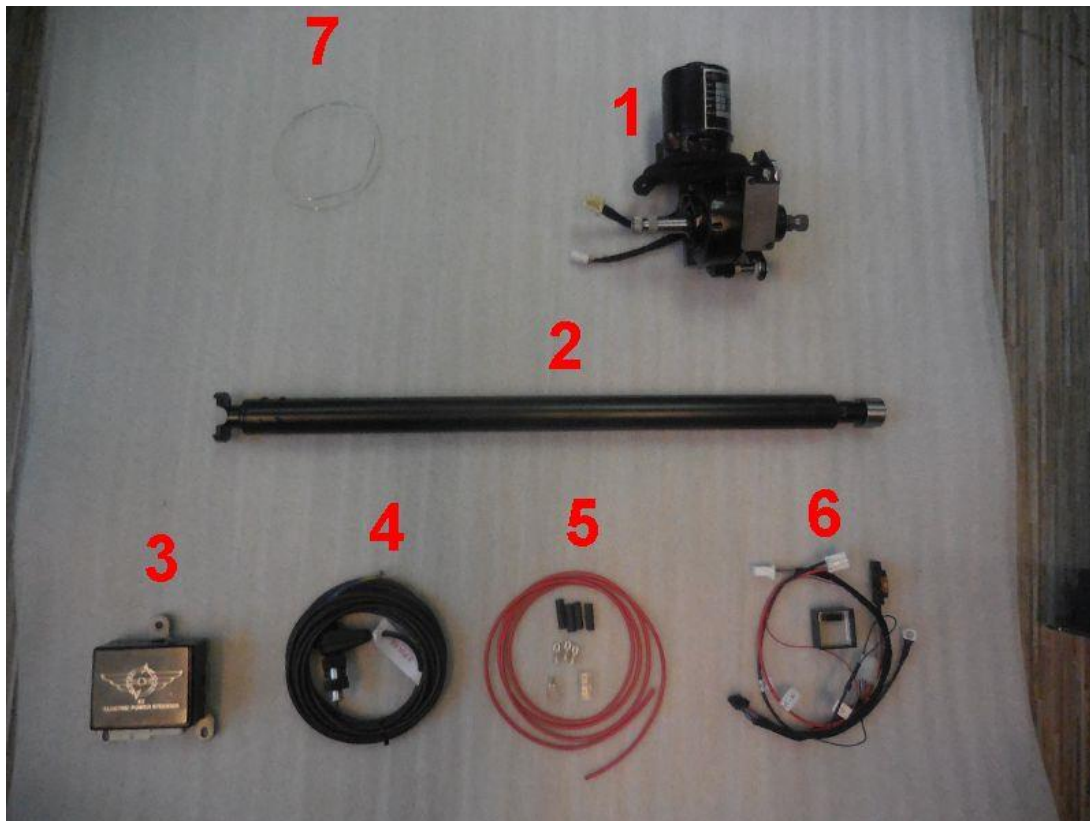

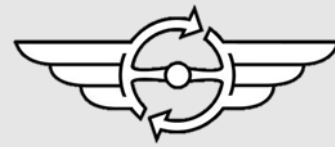

## BEFORE AND AFTER ASSEMBLY



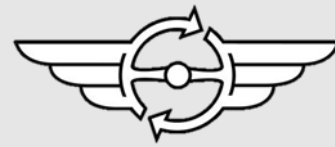

# INSTALLATION

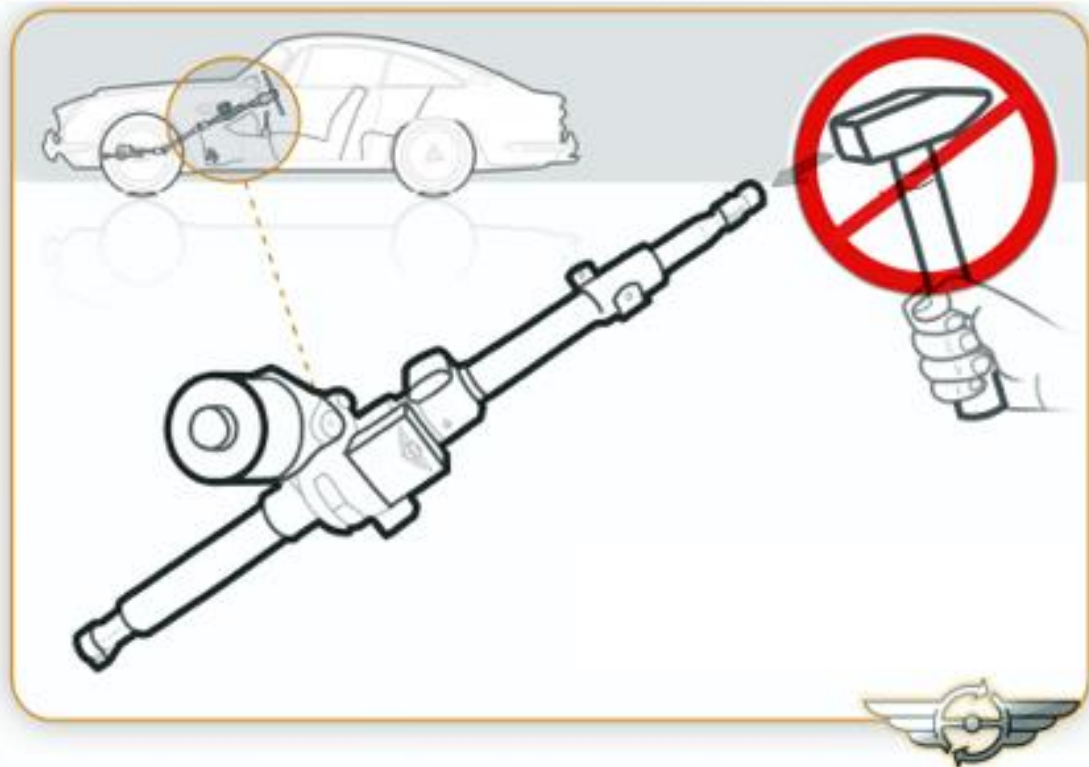

Never strike the input shaft with an object during or after assembly. This can adversely affect the sensors.

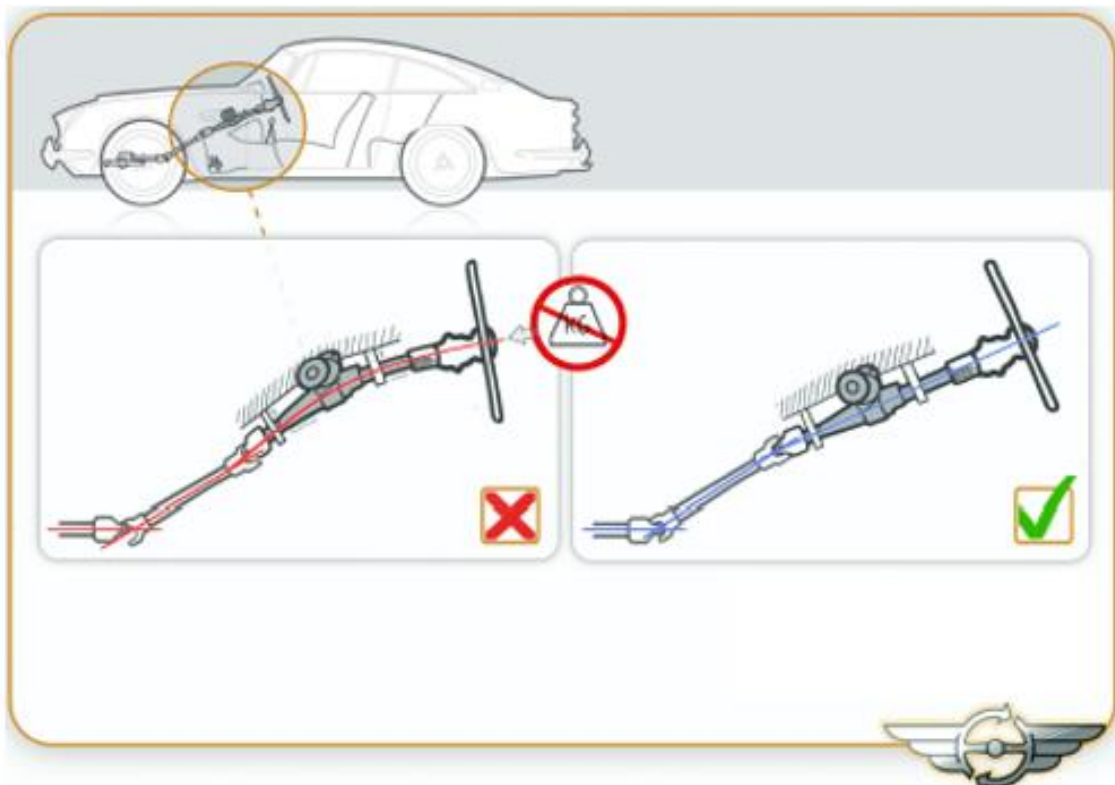

The steering system must always be properly aligned and mounted without tension.

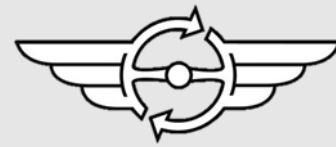

### Step 1.

Check the tire pressure and take a test drive with the car. Check whether the steering wheel returns to the straight-ahead position. Check whether the controls and instruments are defective. If all this is in order, then proceed with the conversion.

### Step 2.

Find a power supply connected via the contact. This is necessary for controlling the EZ power steering unit (see point 18). To do this, disassemble the bottom plate under the dashboard if present, the switched power supply can be removed from the contact lock or the start button. Then disconnect the earth cable from the battery. Make a selection before installation, or put the wheels and steering wheel in the straight-ahead position, mark this position and continue with the conversion. Or determine the center of the wheelhouse by dividing the number of steering turns, from full left to full right, by dividing the two and adjust the wheel alignment after installation, if necessary. Originally there are already markings for the straight-ahead position on the wheelhouse.

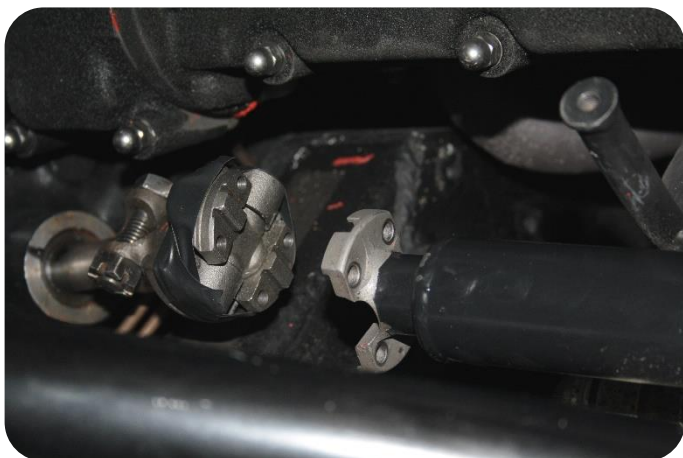

### Step 3.

Loosen the steering tube in the engine compartment. Stick tape around the universal joint in the engine compartment to prevent it from falling apart during dismantling. Cut the locking wire and unscrew the four Allen screws.

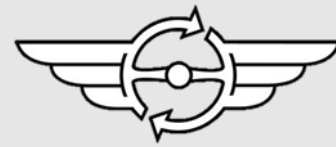

**Step 4.**

Loosen the universal joint under the dashboard. Remove the locking pin. Remove the steering tube. Place the rubber around the steering tube back into the bulkhead.



**Step 5.**

Cut space in the pedal box for the electric motor of the EZ unit. Use the template in the attachment for this. Tighten the universal joint bolts in the engine compartment.



**Step 6.**

In some cases it is necessary to make a small recess. See the photo and supplied template.



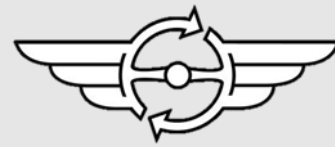

### Step 7.

Loosen the two bolts of the handlebar height adjustment so that it can move freely. This simplifies the assembly of the electric motor.

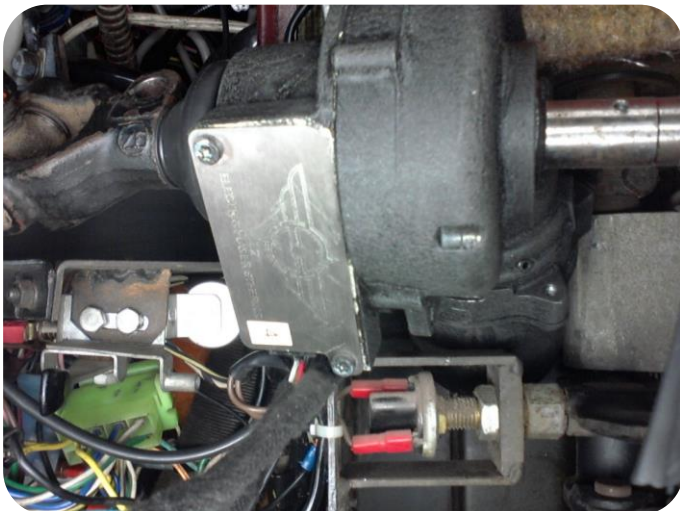

### Step 8.

Install the electric motor as follows. Raise the electric motor along the brake light switch.

### Step 9.

Slide the input shaft of the electric motor into the universal joint of the steering wheel section. Place the bolt in the universal joint, but do not tighten it yet.

Check the straight position on the wheelhouse. Check again if the steering wheel is straight.

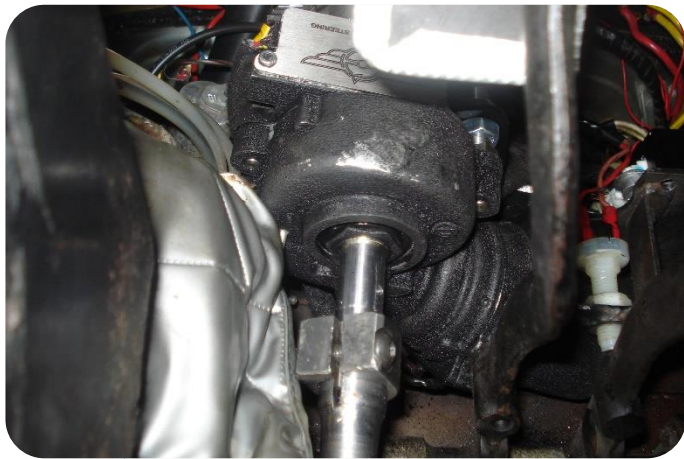
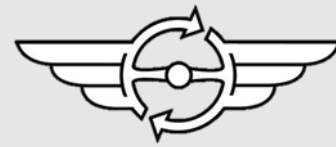

#### Step 10.

Slide the output shaft onto the electric motor.

Check whether the motor fits, is sufficiently free in relation to the pedal box and can turn freely.

Then install two nuts (M10) on the threads of the electric motor.



#### Step 11.

Slide the mounting plate over the wire ends of the electric motor. Attach the plate with two nuts and washers and adjust this plate relative to the pedal box. Mark the holes in the mounting plate. Drill these holes with a 9 mm drill.



### Step 12.

First install the top two bolts in the mounting plate and tighten them. Then tighten the two lower mounting bolts. Ensure that the EZ unit is not mounted under voltage.

### Step 13.

Now tighten the bolts in the universal joint and the handlebar height adjustment. Fit new safety wire in the bolts on the universal joint of the wheelhouse. Install a new split pin on the bolt in the universal joint under the dashboard.

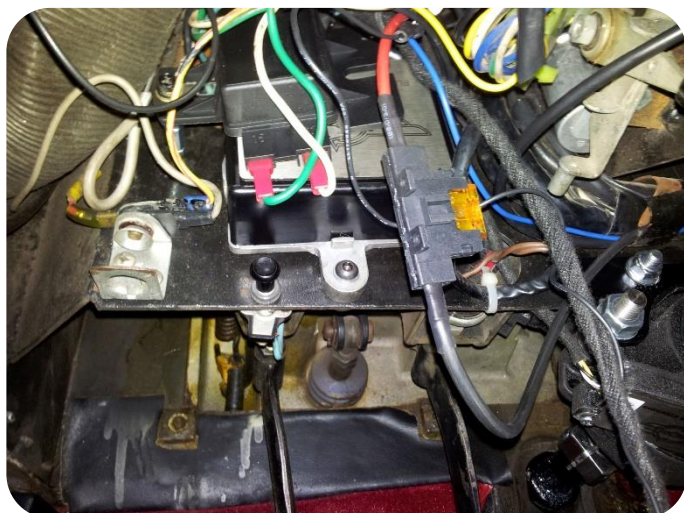

### Step 14.

Mount the computer (with the included support) on the front of the pedal box.

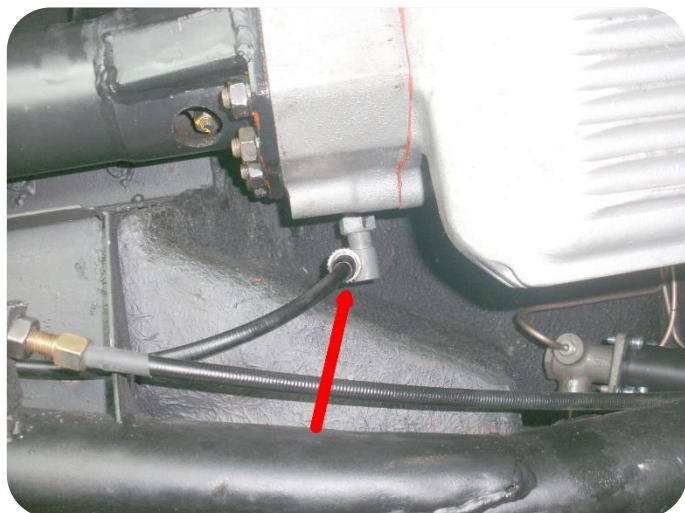
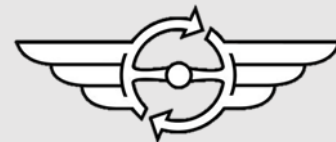

### Step 15.

The speedometer cable comes from the gearbox. Connect the adapter between the gearbox and the speedometer cable. Route the wiring with the existing one towards the computer of the EZ unit. Use tie-wraps for this. Connect the speed sensor with the EZ cable harness, making sure that the wire colors correspond with each other in the plug. Connect the plug of the speed adapter and the steering column and carefully conceal the cable bundle under the dashboard.

### Step 16.

Find a suitable location for the ECU and install it. Then connect the EZ wire set.

### Step 17.

Connect the thick supplied red wire (30+) directly to the battery plus via the fuse holder. It is wise to insulate the wire with an extra sheath.

### Step 18.

Connect the thin red wire (15+) with a contact-switched power supply (see point 2)

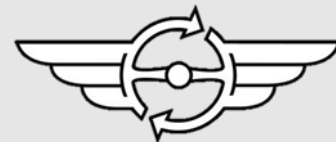

### Step 19.

Connect the black wire (31-) with a suitable clean ground point.

### Step 20.

Install the previously disconnected earth cable from the battery. After switching on the ignition, a click can be heard from the ECU, the system is now operational, check this by making steering movements. After switching off the ignition, another click is heard after approximately 4 seconds. The system is then switched off.

### Step 21.

Re-install the steering wheel of the car. Or mount the handlebar at the position of the center of the wheelhouse and adjust the wheel alignment where necessary. Or mount the handlebar in the marked straight-ahead position. Take a test drive and check all systems again. Also check if the position of the steering wheel is correct, if not adjust it. Please note, ensure that there is sufficient length on the horn wire for adjusting the steering wheel.

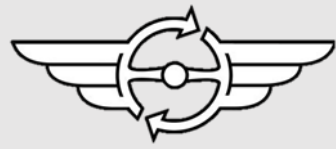

Step 22.

The end result.



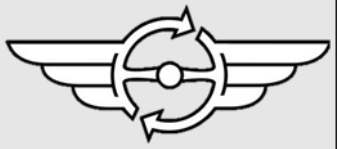

Voorzijde pedaalkouder

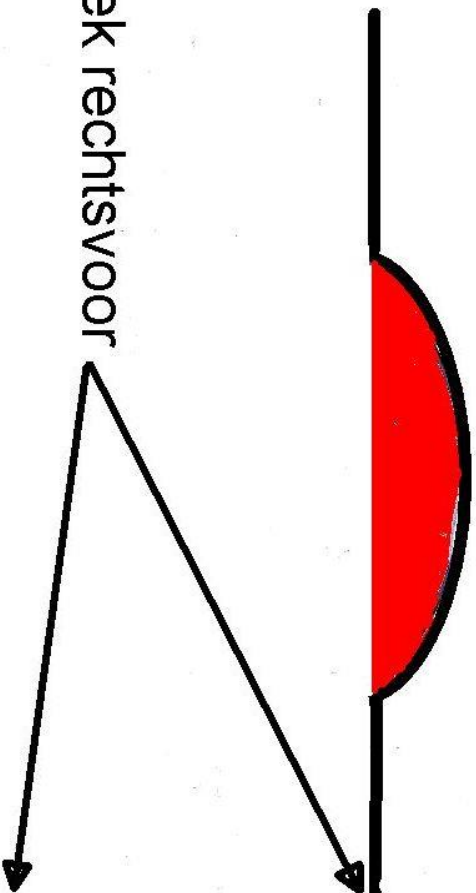

Hoek rechtsvoor

Rechtse zijde pedaalkouder

